

SPI Bus Communication with Sensortech's Digital HCE Pressure Sensors

1 INTRODUCTION

Sensortech's digital pressure sensors are calibrated and temperature compensated with an on-board ASIC, which provides a corrected digital pressure value with up to 15 bit resolution. Additionally an analog voltage output is available at the same time. The response time of the sensor depends on the adjusted internal resolution. For 12 bit it is typ. 0.5 ms.

Sensortech's digital sensors can be configured to comply with SPI or I²C bus protocol.

NOTE:

This application note only refers to SPI bus communication and specifically discusses Sensortech's HCE pressure sensors with SPI compatible protocol.

The Serial Peripheral Interface (SPI) is a simple bus system for synchronous serial communication between one master and one or more slaves (theoretically any amount of slaves would be possible). It operates in full-duplex mode allowing communication to happen in both directions simultaneously. The master device initiates an information transfer on the bus and generates clock and control signals. Slave devices are controlled by the master through individual slave select lines and are active only when selected.

For the data transmission there needs to be two signal and two data lines. These are:

- Slave Select (\overline{SS})
- Signal Clock (SCK)
- Master Out - Slave In (MOSI)
- Master In - Slave Out (MISO)

All bus lines are unidirectional.

SPI Bus Communication with Sensortech's Digital HCE Pressure Sensors

2 BUS ARCHITECTURE

2.1 SCK (Signal Clock)

The clock signal is generated by the master and is connected to all slaves. It is used to synchronise all data transfer.

2.2 \overline{SS} (Slave Select)

Slave devices are addressed and controlled by the master through individual slave select lines. The master selects a slave by pulling the Slave Select line of that slave to LOW. The limiting factor for the amount of slaves in a system is the possible number of Slave Select lines to the master device.

2.3 MOSI (Master Out - Slave In)

The MOSI line transfers data from the master to the slave.

2.4 MISO (Master In - Slave Out)

The MISO line transfers data from the slave to the master.

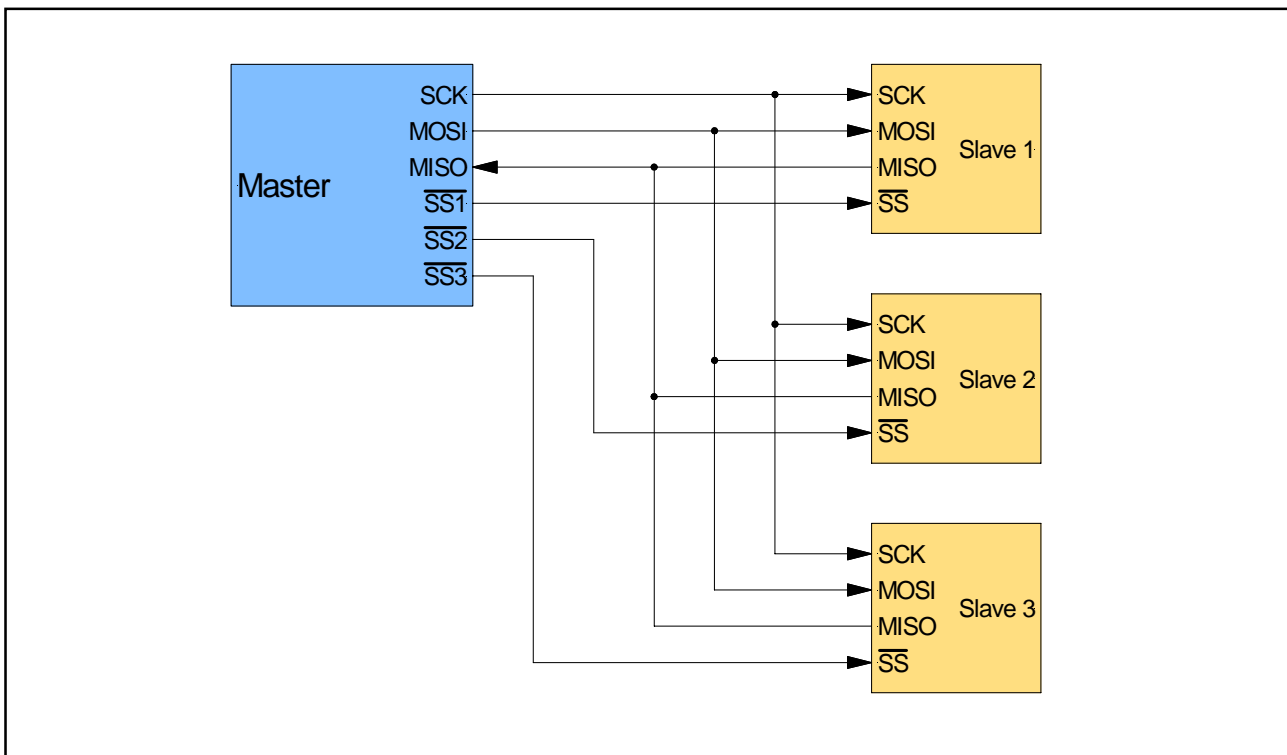

Fig. 1: Sample SPI configuration with one master and multiple slaves

SPI Bus Communication with Sensortech's Digital HCE Pressure Sensors

3 SPI BUS PROTOCOL

3.1 Data Transmission

To start communication, the master first selects a slave by pulling the Slave Select line of this slave down to LOW. The master then writes the data to be transferred into its data transmission register and, after a short delay, transmits the clock signal (see 4.5 Timing).

Data transfer is organised in full duplex mode by using shift registers in both, master and slave devices. With each clock cycle data is pushed from master to slave on the MOSI line while the slave itself pushes data to the master on the MISO line at the same time (see Fig. 2). A data transmission will be finished when the Slave Select line is pulled up to HIGH again.

NOTE:

For Sensortech's digital pressure sensors with SPI bus a MOSI line is not necessary because there is no need for data transmission to the sensor (slave). Therefore, for some applications it makes sense not to connect the sensors MOSI line with the master-microcontroller but to pull up this line to HIGH level with a resistor on the sensor side (see 5 Application Circuit).

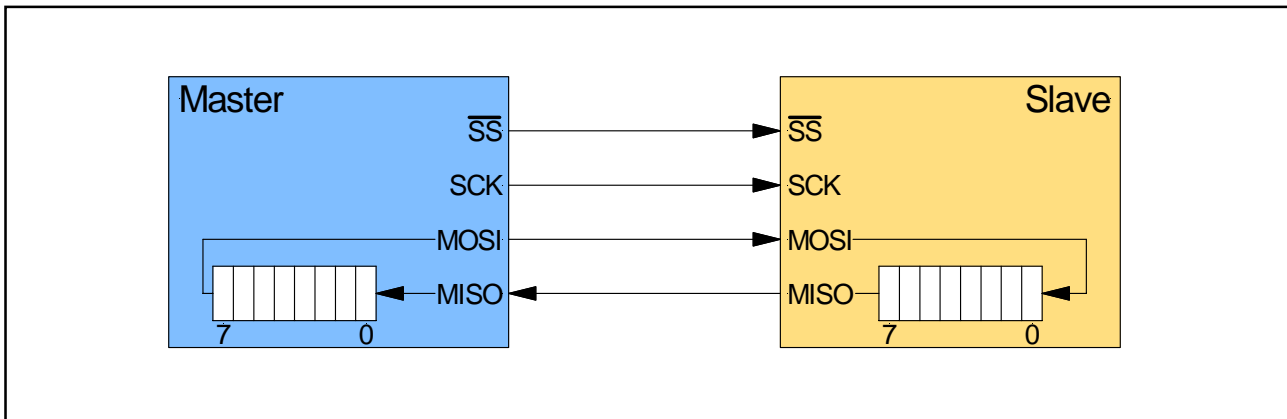

Fig. 2: Data transfer using master and slave shift registers

SPI Bus Communication with Sensortech's Digital HCE Pressure Sensors

3.2 Communication Modes

The SPI protocol specifies the clock signal by two parameters, the clock polarity (CPOL) and the clock phase (CPHA). This results into four possible communication modes (see Table 1). These settings define which clock edge the data will be transmitted and which time the data is allowed to change.

It is important to set these parameters to the same values in both, master and slave devices to ensure proper communication. CPOL and CPHA can be adjusted via two control bits in the SPI control registers.

SPI mode	CPOL	CPHA
0	0	0
1	0	1
2	1	0
3	1	1

Table 1: SPI communication modes

NOTE:

Sensortech's digital pressure sensors are programmed to CPHA = 0 and CPOL = 0 by default. Generally they support all four different modes. Please contact Sensortech for more information.

3.2.1 CPOL (Clock Polarity)

The clock polarity specifies whether the clock signal is LOW (CPOL=0) or HIGH (CPOL=1) in its idle state.

3.2.2 CPHA (Clock Phase)

The clock phase defines at which clock edge the first data is accepted as valid. CPHA=0 means that the data is valid with the first (leading) clock edge. CPHA=1 means that the data is valid with the second (trailing) clock edge.

SPI Bus Communication with Sensortronics' Digital HCE Pressure Sensors

3.3 Transfer format

3.3.1 CPHA = 0

If the clock phase is set to 0 data is valid with the first clock edge. The state of the clock polarity defines whether this first clock edge is a rising or falling edge.

For CPOL=0 the clock value is LOW in its idle state and rises to HIGH with the first clock edge. For CPOL=1 the clock value is HIGH in its idle state and falls to LOW with the first clock edge.

However, the clock polarity does not influence the moment when the first data bit is valid and therefore does not influence the transfer format which is shown in Fig. 3.

NOTE:
Fig. 3 and 4 show the theoretical SPI bus data transfer. For the specific communication characteristics of the HCE pressure sensors please refer to 4.5 Timing.

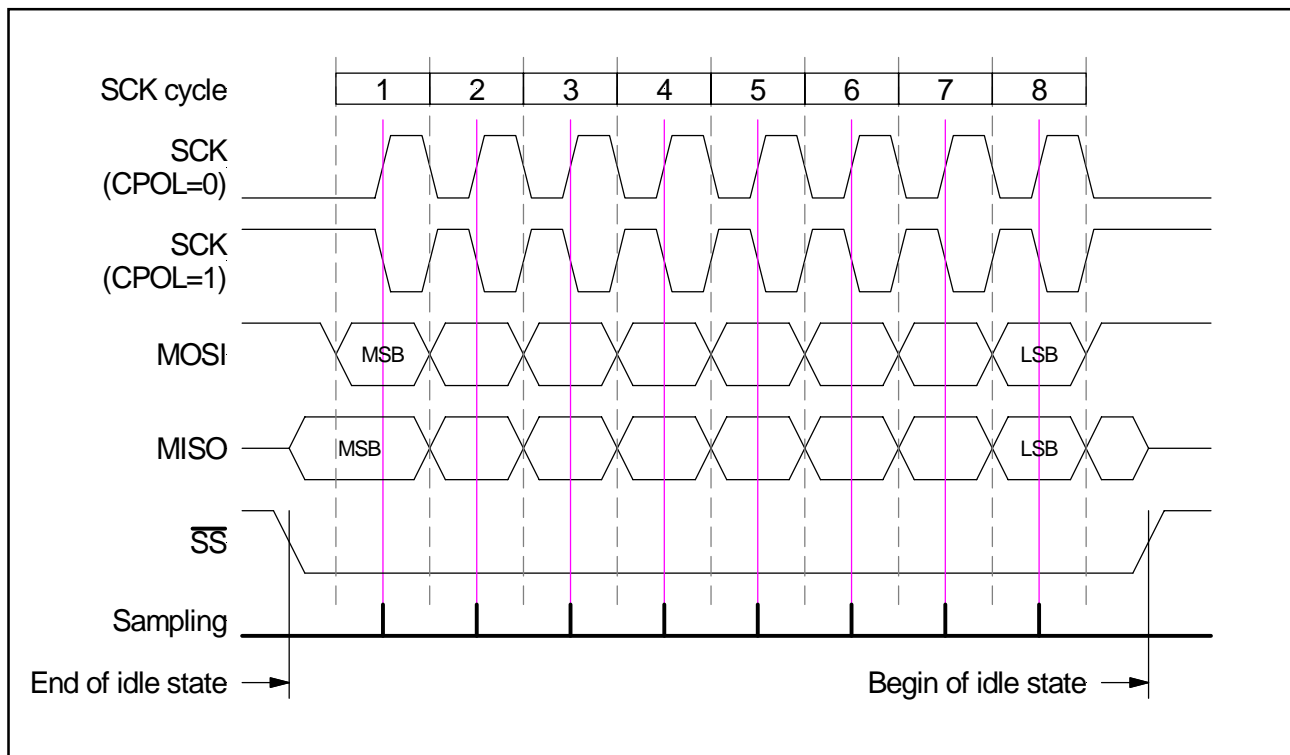

Fig. 3: Example of a 1 byte SPI data transfer for CPHA=0

SPI Bus Communication with Sensortech's Digital HCE Pressure Sensors

3.3.2 CPHA = 1

If the clock phase is set to 1 data is valid with the second clock edge. The state of the clock polarity defines whether this second clock edge is a rising or falling edge.

For CPOL=0 the clock value is in its HIGH state after the first clock edge and is falling to LOW with the second edge.

For CPOL=1 the clock value is in its LOW state after the first clock edge and is rising to HIGH with the second edge.

The clock polarity does not influence the moment when the first data bit is valid and therefore does not influence the transfer format which is shown in Fig. 4.

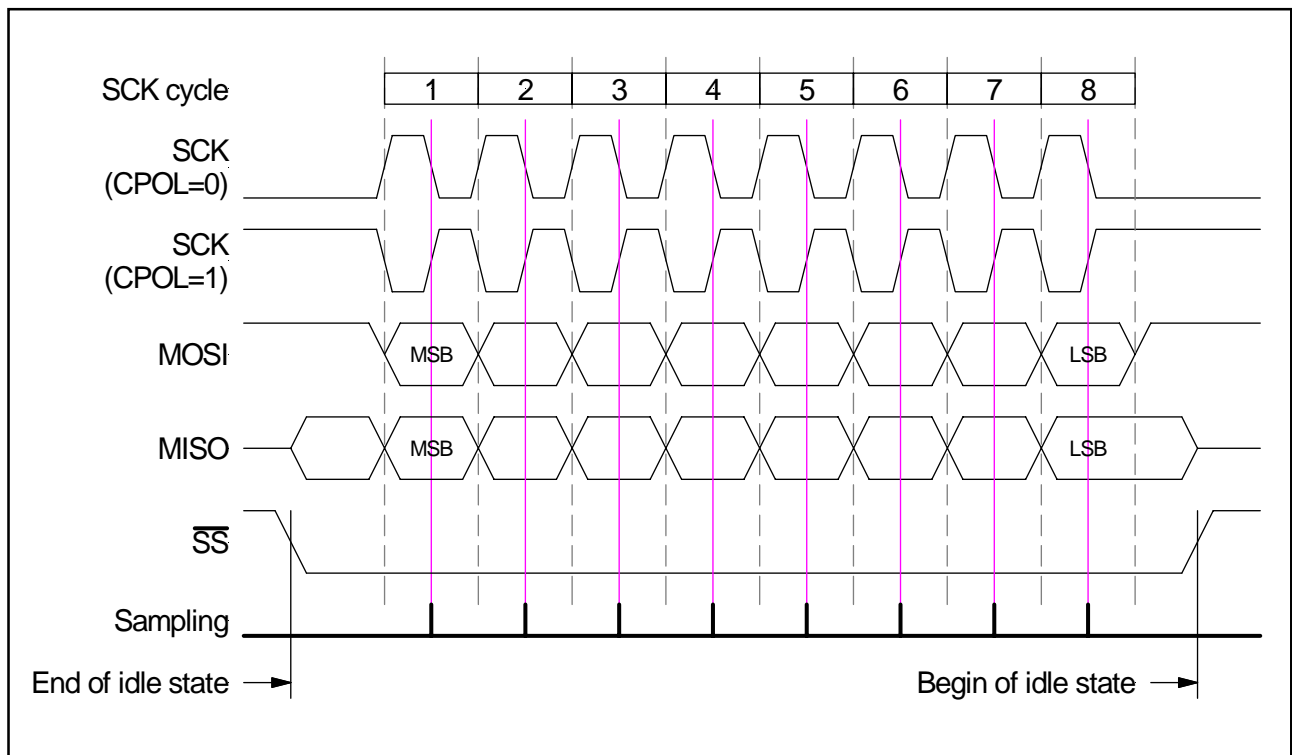

Fig. 4: Example of a 1 byte SPI data transfer for CPHA=1

SPI Bus Communication with Sensortech's Digital HCE Pressure Sensors

4 SPI BUS DATA TRANSFER WITH HCE PRESSURE SENSORS

4.1 Pressure reading

To start communication the master pulls down the Slave Select line to LOW level. The pressure information will be transferred as a 15 bit word within a 3 byte data stream (see Fig. 5). Sensortech's digital pressure sensors are not designed for data reception. Therefore, it is recommended to send only a HIGH level to the sensor so as not to cause any problems or undefined actions. As the master might still send some order to the slave at the beginning of the transfer there is a first byte without any data transmitted by the sensor (the sensor will typically send 0xFFh). The following 2nd and 3rd data bytes contain the current pressure information starting with the most significant bit (MSB) and ending with the least significant bit (LSB). The data transmission will be terminated when the master pulls up the Slave Select to HIGH again.

The sensor is also able to send pressure values "online". That is, if the master does not pull up the Slave Select line after the third exchanged byte the slave will go on sending the last available pressure value when it is clocked. These "online" values are then only 2 bytes long.

4.2 Optional temperature reading

As an option the sensor can be factory configured to deliver an additional 15 bit temperature reading. This will then be

NOTE1:
Sensortech's HCE sensors are configured for a 2 or 3 byte data transfer. Therefore, the Slave Select line must not be pulled up in between the individual bytes of a data stream since this would terminate the communication!

NOTE2:
With a clock frequency of 500 kHz the exchange of the first 3 data bytes takes about 50 µs. The following 2 byte "online" pressure values take another 32 µs each. However, the internal HCE sensor conversion cycle to obtain a new pressure value is 500 µs for 14 bit resolution. Therefore, if the sensor is not deactivated it will send the same digital pressure value at least 14 times before a new reading can be obtained. For further information please contact Sensortech.

transmitted as a 4th and 5th byte after the pressure value. If the master does not pull up the Slave Select Line after the 5th byte the sensor will continue sending alternating 4 byte long pressure and temperature values until it is deactivated.

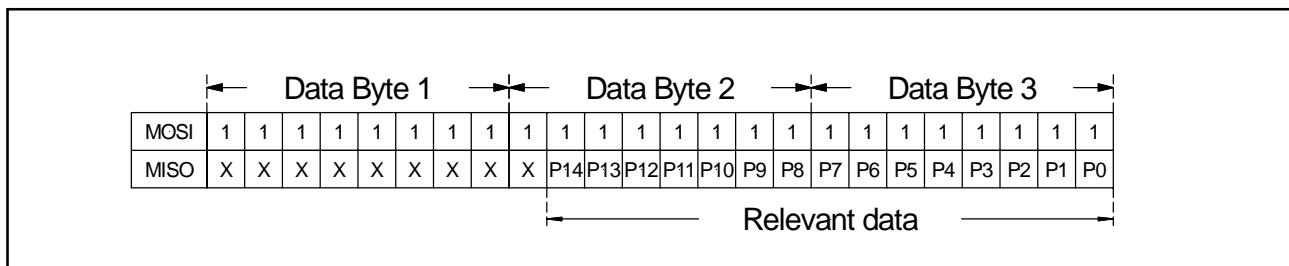

Fig. 5: 3 byte data stream containing the pressure value as a 15 bit information

SPI Bus Communication with Sensortech's Digital HCE Pressure Sensors

4.3 Calculation of the actual pressure value from the digital pressure word

The following formulas show how to calculate the actual pressure value from the digital sensor output:

Definitions:

- S = Sensitivity [counts/mbar]
- Out_{max} = Output @ max. pressure [counts]
- Out_{min} = Output @ min. pressure [counts]
- P_{max} = Max. value of pressure range [mbar]
- P_{min} = Min. value of pressure range [mbar]
- P = Pressure reading [mbar]
- P_{counts} = Digital pressure reading [counts]

$$S = \frac{Out_{max} - Out_{min}}{P_{max} - P_{min}} \quad (1)$$

$$P = \frac{P_{counts} - Out_{min}}{S} + P_{min} \quad (2)$$

The following example shows the calculation for a HCEM100DB... device (pressure range 0...±100 mbar bidirectional). Please refer to the HCE data sheet for the specified calibration values.

$$\begin{aligned} Out_{min} (-100 \text{ mbar}) &= 0666 \text{ hex} = 1638 \text{ dec} \\ Out_{max} (+100 \text{ mbar}) &= 6CCC \text{ hex} = 27852 \text{ dec} \end{aligned}$$

With equation (1) the sensitivity of the sensor gives

$$S = \frac{27852 \text{ counts} - 1638 \text{ counts}}{100 \text{ mbar} - (-100 \text{ mbar})}$$

$$S = 131.07 \text{ counts/mbar}$$

For an actual digital pressure reading of e.g.

$$P_{counts} = 20608 \text{ counts decimal}$$

the actual pressure in mbar can be calculated from equation (2) to be

$$P = \frac{20608 \text{ counts} - 1638 \text{ counts}}{131.07 \text{ counts/mbar}} + (-100 \text{ mbar})$$

$$P = \underline{\underline{44.73 \text{ mbar}}}$$

This pressure reading is calculated with the typical calibration values, not taking into account that the individual sensor calibrations might differ within the tolerances specified in the HCE data sheet.

4.4 Resolution of data

Each temperature and pressure value will be transmitted as a 15 bit word. However, the actual resolution can be less than this depending on how the internal A/D-converter is configured. Also, internal calculations and signal windowing will reduce the effective resolution. For the HCE pressure sensor the standard resolution for pressure measurement is typ. 14 bits. For temperature measurement the limiting factor is the sensitivity of the sensing element. For further information please contact Sensortech.

SPI Bus Communication with Sensortech's Digital HCE Pressure Sensors

Parameter	Symbol	Min.	Typ.	Max.	Unit
Input high level		90		100	% of V_s
Input low level		0		10	
Output low level				10	
Pull-up resistor		500			Ω
Load capacitance @ MISO	C_{MISO}			400	pF
Input capacitance @ each pin	C_{SPLIN}			10	
Signal clock frequency	f_{SCK}	100*		640	kHz
MISO hold time after SCK sample slope	$t_{SPL_HD_MISO}$	200			ns
MOSI setup time before SCK sample slope	$t_{SPL_SU_MOSI}$	$2/f_{CLK}$			
/SS setup time before SCK sample slope	$t_{SPL_SU_SS}$	10			ns
/SS hold time after SCK sample slope	$t_{SPL_HD_SS}$	$1/f_{CLK}$			

* recommended (see note on page 10)

Table 2: SPI bus timing and communication parameters for Sensortech's digital pressure sensors

4.5 Timing

To ensure correct communication the sensor must be able to detect the start condition (pull down of Slave Select line) before the master sends the first clock signal. Therefore, a minimum delay time $t_{SPL_SU_SS}$ is required prior to the first clock edge (see Table 2 and Fig. 6). Further, after the last clock edge of the data transfer a minimum delay time $t_{SPL_HD_SS}$ is required before the master pulls up the Slave Select line to terminate the communication.

The correct timing has to be controlled by the master and is influenced by the following conditions:

- the SPI communication mode
- the communication speed
- the application circuit (e.g. the values of the pull-up-resistors)
- the load capacitances and impedances of the SPI bus lines
- ... and others

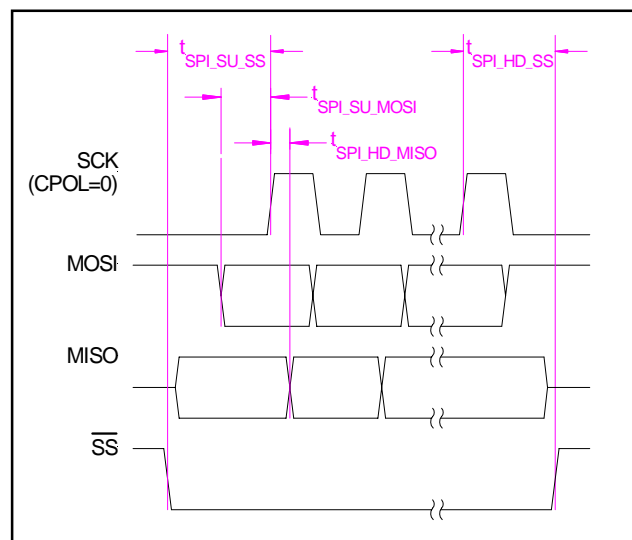

Fig. 6: SPI bus timing characteristics

The HCE pressure sensors change their data after $t_{SPL_HD_MISO}$ very shortly after the valid clock edge (see Fig. 6). This does not correspond to the theoretical transfer format as shown in Fig. 3, page 5. Therefore, especially for low communication speeds there can be the wrong impression as if the data transfer would take place with the falling clock edge (CPAH=1, CPOL=0, compare Fig. 4 page 6).

SPI Bus Communication with Sensortechinics' Digital HCE Pressure Sensors

4.6 Communication Parameters

The maximum allowed communication speed depends on the configured internal clock frequency of the sensor which varies with temperature and production conditions. For the worst case scenario the maximum allowed clock frequency in standard configuration is 640 kHz. As a special configuration this can be increased to 730 kHz.

4.7 Signal Noise due to Communication

As the pulses transmitted on the bus lines have very sharp edges, this can cause some electromagnetic interference. Especially for very low pressures and small PCB designs, these spikes can influence the analog millivolt measurement of the sensor bridge and downgrade signal quality.

NOTE:

To prevent signal noise Sensortechinics recommends a min. clock frequency of 100 kHz (max. 640 kHz) and transmission breaks of min. 500 μ s between two pressure readings. This is especially valid for low pressure devices up to 25 mbar. Please contact Sensortechinics for more information.

If both digital and analog interfaces are used in parallel it is recommended to separate these lines as far as possible from each other. Further, decoupling capacitors of 220 nF between supply and ground and 15 nF between the analog output and ground are beneficial. It is important to place the capacitors as close to the pins as possible.

5 APPLICATION CIRCUIT

All bus lines have to be connected to the supply voltage via pull-up resistors (see Fig. 7). Resistors of about 4.7 k Ω are recommended. Additionally, 330 Ω serial resistors should be used in each communication line.

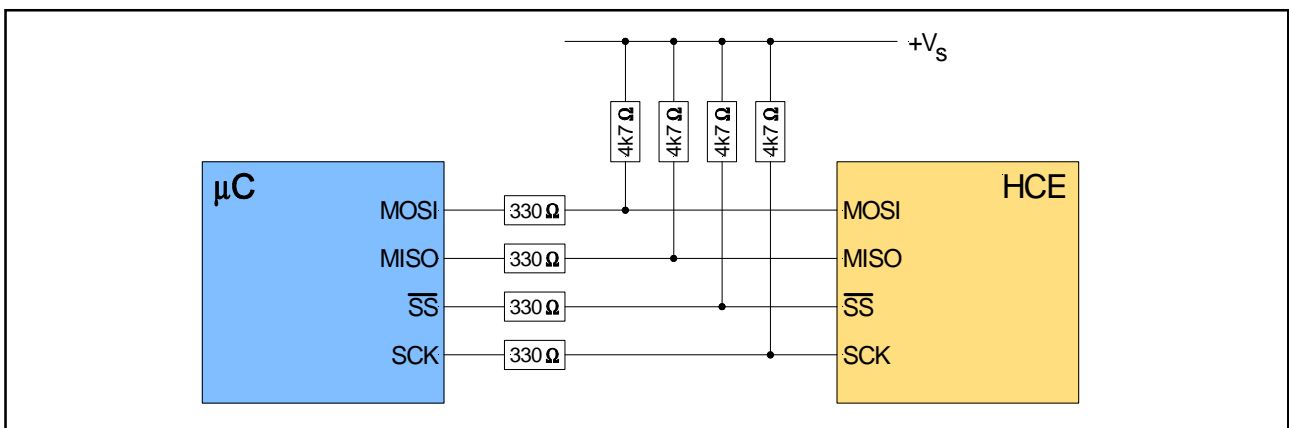

Fig. 7: SPI bus application circuit for Sensortechinics' HCE pressure sensors

SPI Bus Communication with Sensortechncs' Digital HCE Pressure Sensors

6 SAMPLE PROGRAM CODE

```
byte dont_care;           // 8bit values
byte byte_msb, byte_lsb; // 8bit values
int16 pressure;          // 16bit value

// If your controller does not control the /SS pin, you'll need to configure it yourself
// Set output value to 1/high state (SPI in idle state)
pin_ss = 1;
// Set pin to output
set_inout_mode(pin_ss, PIN_OUT);

// Set SPI unit to SPI master mode, clock speed 100 kHz and SPI mode 0 (CPHA = 0 & CPOL = 0)
configureSPI (SPI_MASTER | CLK_SPEED_100KHZ | SPI_MODE_0);

// Set /SS Pin low (Start communication)
pin_ss = 0;
// Transfer one byte over SPI bus (send 0xFF, write received data to dont_care (discard first byte))
SPI_transfer (0xFF, &dont_care);
// Transfer one byte over SPI bus (send 0xFF, write received data to byte_msb)
SPI_transfer (0xFF, &byte_msb);
// Transfer one byte over SPI bus (send 0xFF, write received data to byte_lsb)
SPI_transfer (0xFF, &byte_lsb);
// Set /SS pin high (End communication)
pin_ss = 1;

// Put both values together
pressure = ((int16)byte_msb << 8) | byte_lsb;
```

7 TROUBLESHOOTING

7.1 Sensor does not respond

- Check the signal levels at the SCK and Slave Select pins of the sensor:
 - Are the edges sharp enough?
 - Are the HIGH and LOW levels within the specified range (compare Table 2)?
- Check the analog output signal of the sensor. If it responds to pressure changes the sensor works.

7.2 Sensor supplies unstable data

- Check the used SPI communication mode. By default Sensortechncs' HCE pressure sensors are programmed to CPAH=0 and CPOL=0.
- Have the advices regarding signal noise under point 4.7 been followed?

For more information please contact Sensortechncs:

***www.sensortechncs.com/contact
info@sensortechncs.com***